

The Influence of Leadership, Motivation and Discipline on Organizational Commitment and Its Impact on Employee Performance at the Agriculture Office in Pidie Regency

¹Zulkifli, ²Cut Italina,

¹Faculty of Economics at Jabal Ghafur University, Sigli, Indonesia

²Faculty of Economics at Jabal Ghafur University, Sigli, Indonesia

E-mail: zulkifli@unigha.ac.id

ARTICLE INFO

Article history:

Received: 13-07-2020

Revised: 13-07-2020

Accepted: 31-07-2020

Keywords:

Leadership, motivation, Discipline, Organizational Commitment and Employee Performance

ABSTRACT

The purpose of this research was to determine the influence of empirical evidence of the leadership, motivation and discipline toward organization commitment. All of these were effected to the employee performance at the government duty of agriculture of Pidie district. The data used were primer and secondary from 125 respondents. Structural Equation Modeling (SEM) was used as the data analysis method and helped by AMOS 21. The result showed that the leadership, motivation and discipline variable had a positive impact toward *organization* commitment. They also had positive influence toward the employee performance. While the variable of mediation testing showed that organization commitment mediated the correlation among leadership, motivation and discipline fully toward the employee of the government duty of agriculture in Pidie District Area.

Copyright © 2020 Journal of Management Science (JMAS).
All rights reserved.

1. Introduction

The success of an organization is largely determined by its ability to transform itself in accordance with change and support a culture that supports organizational goals. The organization over the era of continuous improvement is determined by the ability of the organization to develop its human resource potential. The more aware the employee is the most important resource in the organization, the employee's performance is crucial for the overall organization. Without high-performing employees, the organization will fail to reach meetings. The success of an organization requires the support of its individual employees, an organization will increase the need for its employees in the hope that the company can obtain. Performance is basically what employees do or don't do. According to Riva'i (2009), the results are the results or the results of the level of success, during a certain period in the implementation of the task, in accordance with the standards of work, targets or targets or agreements that are predetermined and have been agreed together in accordance with Mangkunegara (2012) provide high quality work that is requested by an employee who performs the tasks as requested. Thus, performance is important for the organization or company and for the employee itself, therefore employee performance will run with effectiveness supported by leadership, motivation, discipline and organizational commitment. The phenomenon that is happening right now is that the Pidie Regency Agriculture Service Office is a Government Institution that serves the community, farmers, farmer groups, and entrepreneurs in agriculture and mining. In a dispute only requires high performance on employees, without looking at the factors that influence. While fundamental factors in supporting performance such as leadership, motivation, discipline and organizational commitment within the company must also be considered in order to increase employee productivity. In the current era of globalization, service improvement and community recovery is an unavoidable condition, this clearly demands professionalism in the bureaucracy. Pidie Regency Agricultural Service officials as state apparatus must create creative, do more effective and efficient work, in this case the leaders of the institutions need to increase motivation, discipline and organizational commitment, so that the purpose of the relationship can help and will improve employee performance.

Based on preliminary observations made by researchers, the problems that occur in the District Agricultural Office in Pidie, leadership, motivation, discipline and organizational commitment within the organization are still lacking. This can be proven by looking at the situation directly at the Pidie District Agriculture Office. Judging from the leadership in the Department of Agriculture in Pidie Regency, leaders do not understand the situation when employees are at work, never give awards to employees who excel at work, leaders have no creativity in leading, are unable to create discipline for their employees and never provide special guidance to employees who works at the Pidie Regency Agriculture Office. Judging from the motivation given at the Agriculture Service in Pidie Regency, employees have no sincerity in working, lack of sense of responsibility in completing tasks, no desire to improve good profession in the organization, lack of determination in dealing with pressure at work and always have concerns will fail in completing the task. Judging from the discipline, many employees do not understand the objectives at work and lack the ability to complete their duties, do not have good examples of fellow employees and the community who come to the Office of Agriculture in Pidie District, no sense of retaliation towards their leaders, do not receive justice the same as other employees in the organization, lack of supervision (inherent supervision) in the organization, employees always receive legal sanctions against employees who have made mistakes and all employees in the Agriculture Service in Pidie Regency also receive firmness from the leader to complete their duties properly so as to make employees depressed when on duty so as to cause employee performance to get worse. Judging from the commitment of the organization to the Department of Agriculture in Pidie District, leaders are not loyal in giving trust to employees who work, lack of concern gained from leaders, lack of joy in completing tasks, employees feel leaders do not have pride to employees who have completed their duties properly, employees always receive the trust given by their leaders, the loss of employee loyalty in the Department of Agriculture in Pidie Regency and there are some employees taking care to move to other agencies and the organization has been less inspiring to its employees.

Due to lack of leadership, motivation, discipline and organizational commitment at the Pidie District Agriculture Office, employee performance has been declining over time so it needs to be improved so that the organization gets better, lack of employee performance is seen because employees do not have the quality and quantity at work, many employees are completing their duties on time as expected by the leader, the lack of effectiveness of employees when completing their tasks so that many jobs do not reach their completion targets, the lack of independence of the employees themselves and employees in the Agriculture Service Office of Pidie Regency do not have commitment while on duty. Based on the above problems, the researcher is interested in conducting research with the title "The Effect of Leadership, Motivation and Discipline on Organizational Commitment and Its Impact on Employee Performance at the Agriculture Service in Pidie Regency.

2. Research Methods

Data collection method used in this study is to use a questionnaire instrument, which is a set of written questions to get information from respondents Malthora (2007) in Adami 2016. In this research questionnaire sheet there are two types of questions or statements, namely (1) questions relating to Measurement of research variables: (2) questions related to respondent data. Questionnaires are made with statements or structured questions and provide answers in the form of scales with answers that are tailored to questions or statements making it easier for respondents to answer and avoid bias. The measurement used is a Likert Scale where each statement has an answer that is 1 (strongly disagree), 2 (disagree), 3 (neutral), 4 (agree) and 5 (strongly agree). According to Imam Ghozali (2005), a Likert Scale is a scale that contains 5 levels of preference with answer choices namely: 1 (Strongly disagree), 2 (Disagree), 3 (Doubtful), 4 (Agree) and 5 (Strongly agree).

Table 1
Likert Scale

No	Category	Weight
1	strongly agree (SA)	5
2	Agree (A)	4
3	Netral (N)	3
4	Disagree (D)	2
5	Strongly disagree (STS)	1

Source: Sugiono (2011).

In addition, the documentation study was also carried out by collecting and studying supporting documents relating to research obtained directly from the Pidie District Agriculture Office.

1) Indicator of Leadership Variable

In this study, the indicators used are Hersey and Blanchard, (2012: 74), consisting of:

- a. Clarity in reading the situation,
- b. Giving awards,
- c. Creativity in leadership and
- d. Creating discipline and
- e. Provide guidance

These indicators can be described as follows:

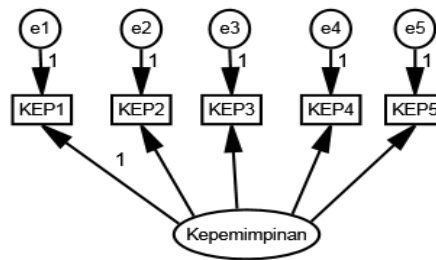

Fig 1. Leadership Variable

2) Indicator of motivation Variable

According to Suwanto and Pransia (2011) that work motivation can be measured through indicators as follows:

- a. Seriousness.
- b. A sense of responsibility
- c. The need for good work performance
- d. Perseverance at work
- e. Fear of failure

These indicators can be described as follows:

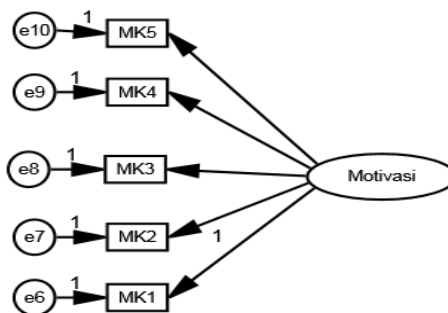

Fig 2. motivation Variable

3) Disciplinary Variable Indicator (KD)

According to Hasibuan (2005: 194-198) basically indicators of employee discipline in an organization, including

- a. Purpose and ability.
- b. Exemplary leadership
- c. Reply services
- d. Justice
- e. Beware
- f. Legal sanctions
- g. Assertiveness
- h. Human relations

These indicators can be described as follows:

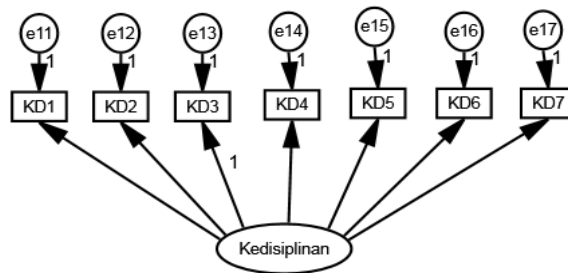

Fig 3. Disciplinary Variable

4) **Indicator Variable Organizational Commitment (KO)**

According to Moydays, Steers and Porter (in Mas'ud 2004) there are several organizational commitment indicators.

- a. Loyalty to the organization (KO1)
- b. Concern for the Organization (KO2)
- c. Happy to choose to work (KO3)
- d. Pride to be part of an organization (KO4)
- e. Accept all work assigned by the organization (KO5)
- f. Loyalty to the organization (KO6)
- g. Organizations that inspire (KO7)

These indicators can be described as follows:

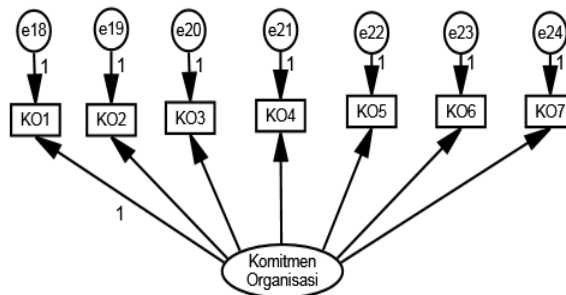

Fig 4. These indicators can be described as follows:

5) **Variable Indicator**

According to Fadel (2009: 195), there are several indicators of employee performance including;

- a. Quality
- b. Quantity
- c. Timeliness
- d. Effectiveness
- e. Independence
- f. Commitments

The models developed in this study are as follows:

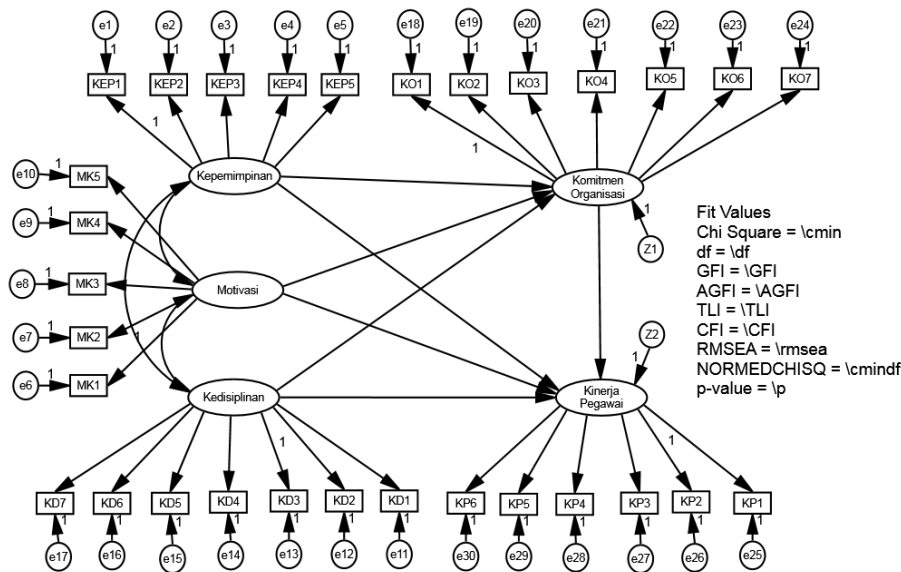

Fig 5. Structural Model

3. Research Result

Based on the results of research that has been obtained through data analysis by using amos on the SEM model to start the following. Discussion of the results of this study will support the theories that support and previous research. This section will discuss the testing of hypotheses that have been prepared with the aim of getting answers to hypotheses and answering them with theories and empirical evidence from previous research. Based on the results of data analysis on the research that has been done, it can be discussed as follows:

a. Effect of Leadership on Organizational Commitment

The results of this study indicate that there is an influence between the leadership variables on organizational commitment in the Department of Agriculture in Pidie Regency. This influence is proven by the standardized estimate coefficient value of 0.501 with a critical ratio (CR) value of 5.292 and a significance of $0.000 < 0.05$ (5%) The results of this study prove that the first hypothesis stating that leadership has a positive and significant effect on organizational commitment can be accepted or H1 received. This means that if leadership in the Pidie District Agriculture Office is measured by several indicators such as the ability of leaders to read the situation, giving awards to subordinates, discipline in work and always providing guidance, so that work commitment will grow in order to improve the performance of employees at the District Defense Office Pidie.

The relationship between leadership and organizational commitment of employees is inseparable from several factors, and one of them is influenced by leadership behavior. Leaders who have expertise in leading, will always be liked and respected by subordinates. According to Mitzberg (1997: Rost, 1991) in Yulk (2005) states that the role of leadership includes motivating subordinates and creating pleasant conditions in carrying out their work.

The results of this study support the theory of experts to see the relationship between leadership and organizational commitment is very close, where the behavior of leaders in running leadership affects the loyalty, trust and loyalty that a person has towards the organization. Rowden (2000) states, leader sensitivity to the needs of members is clearly related to organizational commitment. One explanation for this is that it is unlikely that someone will commit to an organization where the leader is not aligned with his needs. The way leaders influence subordinates to be more able to do or try in order to achieve organizational goals. Siagian (1997) argues that the role of leaders in the organization is very central in achieving the objectives of the various targets previously set. Leadership has a function of determining the direction in achieving goals, representatives and spokespersons of the organization, communicators, mediators and integrators.

b. Effect of Motivation on Organizational Commitment

The results of data analysis with Amos show that there is an influence between the motivational variables on organizational commitment at the Pidie District Agriculture Office. This influence is proven by the standardized estimate coefficient value of 0.335 with a critical ratio (CR) value of 3,811 and a significance of 0,000 <0.05 (5%) The results of this study prove that the second hypothesis which states that motivation has a positive and significant effect on organizational commitment is acceptable or H2 received. This means that if the work motivation among employees at the Pidie District Agriculture Office as measured by several indicators such as sincerity in working, having responsibility, fortitude and always wanting to succeed so far goes well, then employee motivation will obviously increase and be felt by the employee itself, so that work morale will grow in order to improve the performance of the employees of the Office of Agriculture in Pidie Regency.

According to Hasibuan (2001) explains, that motivation can generally be identified as a series of driving forces that arise from within and outside of each individual. These two forces generate interest in work and relate to behavior and determine the direction, intensity, and duration of individual behavior or habits. Mursinta's research results (2009) showed a positive influence between motivation on employee performance. The success of the goals or objectives of the Government / Office Intansi is dependent on employee performance where the employee's performance is strongly influenced by the level of individual motivation. For this reason, a leader must give and try to pay attention to the work motivation of the employees so that they have a high self-will to provide good performance.

c. Effect of Discipline on Organizational Commitment

The results of data analysis with Amos showed that there was an influence between the disciplinary variables on the organizational commitment of employees in the Pidie District Agriculture Office. This influence is proven by the standardized estimate coefficient of 0.449 with a critical ratio (CR) of 4.745 and a significance of 0.000 <0.05 (5%) The results of this study prove that the third hypothesis stating that discipline influences organizational commitment is acceptable or H3 is accepted . This means that if the discipline of employees at the Office of Agriculture in Pidie Regency as measured by several indicators such as ability, fairness, sanctions imposed by the agency and firmness of superiors can increase organizational commitment, so that employee discipline in the agricultural service will increase organizational commitment and ultimately employee performance can be improved too.

According to Haiman (Nawawi, 2003) discipline is an orderly condition, with members of the organization behaving appropriately and viewing organizational regulations as acceptable behavior. Discipline should be voluntary, obedient and obedient and willing to accept sanctions if they violate the rules set by the government agency, for example there is an awareness of willingness to obey the rules, willingness to be responsible, the ability of individuals to do work with honest attitude.

d. Effect of Leadership on Employee Performance

The results of data analysis with Amos show that there is an influence between leadership variables on employee performance in Agriculture in Pidie District. This influence is proven by the standardized estimate coefficient of 0.312 with a critical ratio (CR) of 2,809 and a significance of 0.005 <0.05 (5%) The results of this study prove that the fourth hypothesis that states that leadership has a positive and significant effect on employee performance is acceptable or H4 received. This means that if the leadership applied at the Agriculture Service Office in Pidie Regency can improve the performance of the employees themselves, then the leadership behavior and style applied to the service becomes an example for employees so that their performance also increases with the leadership improvement.

The leadership that is applied to these agencies having expertise in leading an organization will encourage employee performance improvement. According to Lodge and Derek, (1993) that the role of leadership has a significant impact on employee attitudes, behavior and performance. This gives meaning that pernipip plays a big role in improving the performance of subordinates. According to Hasibuan (2009), a leader is someone who uses his authority and leadership, directs subordinates to do some of their work in achieving organizational goals.

Leadership (leadership) set by a manager in the organization can create harmonious integration and encourage employee passion to achieve maximum goals. The results of this study support previous research conducted by Kistoyo (2008) entitled The Effect of Leadership, Communication and Work Environment on Employee Performance at the District Education Office in Pekalongan.

e. Effect of Motivation on Employee Performance

Based on the results of data analysis shows that there is an influence between the motivational variables on employee performance in the Department of Agriculture, Pidie Regency. This influence is

proven by the standardized estimate coefficient of 0.210 with a critical ratio (CR) of 2,322 and a significance of 0.020 <0.05 (5%). The results of this study prove that the fifth hypothesis that states motivation has a positive and significant effect on employee performance can be accepted or H5 is accepted. This means that if the motivation of employees at the Pidie District Agriculture Service Office, can improve the performance of the employees themselves, so that they will grow in the spirit of work in order to improve the performance of Pidie District Agriculture Service Office employees.

Work motivation can be explained in this study as the need to encourage actions for a particular purpose. So employees at work can cause enthusiasm or encouragement to work in an organization (Anoraga, 2005). Yulk (1998) uses the term proficiency which contains a broader meaning. Performance includes aspects of uasaha, potential loyalty, leadership, and work morale. Encouragement and sting as well as the behavior exhibited by someone at work will get real results or outcomes achieved by workers, and assessment of factors such as motivation, commitment to initiative, leadership potential.

The results of this study are in accordance with the theory from Mangkunegara (2005) which states that the factors which affect performance are the ability and communication factors. While Mathis and Jackson (2001) stated that the performance sought by a company from someone depends on the ability, motivation, and support individuals receive. In addition Munandar (2004) performance (performance) is the result of the interaction between work motivation, abilities and opportunities. Previous research that can be the author's reference in formulating the seventh hypothesis statement in this study is a study conducted by Purwati (2012) which examined the effect of work motivation on the performance of PT. Anindya Yongyakarta International Partner. The results show a positive and significant influence of work motivation on employee performance. Other researchers conducted by Agusta (2013) concluded that work motivation has a positive and significant effect on the performance of employees of CV Haragon Surabaya.

f. Effect of Discipline on Employee Performance

The results of the data analysis showed that there was an influence between the disciplinary variables on employee performance in the Department of Agriculture in Pidie District. This influence is proven by the standardized estimate coefficient of 0.247 with a critical ratio (CR) of 2,372 and a significance of 0.018 <0.05 (5%) The results of this study prove that the sixth hypothesis stating that discipline has a positive and significant effect on employee performance can be accepted or H6 received. This means that if the level of employee discipline at the Pidie District Agriculture Office, it can improve the performance of the employees themselves, so that they will grow up working spirit in order to improve the performance of Pidie District Agriculture Department employees.

According to Setiyawan, et al (2006) and states that employee work discipline is part of the performance factor. Work discipline in order to support the achievement of organizational goals because it is a form of compliance with work rules and also as a personal responsibility towards the company. Implementation of discipline based on awareness and conviction will create a harmonious condition between desire and reality. To create a harmonious condition, it must first be realized harmony between obligations and employee rights. So it can be concluded that discipline is an attitude of loyalty and obedience of a person or group of people to the rules both written and unwritten, which is reflected in the form of behavior and deeds. This proves if employee discipline has an influence on employee performance.

g. Effect of Organizational Commitment on Employee Performance

Based on the results of the study showed that there is an influence between the variables of organizational commitment to employee performance in the Department of Agriculture, Pidie Regency. This influence is proven by the standardized estimate coefficient of 0.456 with a critical ratio (CR) value of 2.713 and a significance of 0.007 <0.05 (5%) The results of this study prove that the seventh hypothesis stating that organizational commitment has a positive and significant effect on employee performance is acceptable or H7 received. This means that if the influence of employee commitment at the Office of Agriculture in the District of Pidie on employee performance, so now employees feel committed to working in the agency, loyalty to the organization, and concern for the organization so that the performance of the Office of the Agriculture Office of the District of Pidie can affect commitment of the employee organization.

Mangkunegara (2000) states that performance is the result of quality and quantity of work achieved by a person in carrying out tasks in accordance with the responsibilities given to him. This is because the organizational commitment of the work itself is a source for increasing employee enjoyment and comfort in working so that it will get good employee performance. The results of this study also support research

that explains the relationship between organizational commitment to performance one of which is a study conducted by Yenny (2011) entitled *The Effect of Organizational Commitment, Participation and Motivation on Employee Performance at PT Bank Lippo Tbk Kudus Branch*. The results of this study indicate that organizational commitment has a positive and significant effect on employee performance in the company.

4. Conclusion

Based on the formulation of the problem, the purpose of research, the formulation of hypotheses and the results of analysis of research data, it can be concluded as follows:

- a. Leadership provides a positive and significant impact on organizational commitment to the Department of Agriculture in Pidie District, in other words the leader must always be committed to paying attention to his subordinates for the creation of good employee work.
- b. Motivation has a significant positive effect on the organizational commitment of employees at the Pidie District Agriculture Office. In other words work motivation can be increased if there is a commitment from the leadership in encouraging paying attention to subordinates to work better.
- c. Discipline is achieved well, if there are strict rules or sanctions against undisciplined subordinates.
- d. Good leaders are those who usually guide them to be more disciplined in order to achieve good performance.
- e. In other words, performance will be achieved well if leaders can direct and encourage employees to be more creative and their work is assessed by rewards.
- f. Good performance is achieved when disciplined well.
- g. Employee performance is achieved when there is commitment and loyalty of the leadership in directing subordinates.

5. References

- [1] Adami Chazawi, 2016, *Hukum Pidana Korupsi di Indonesia*, Jakarta, PT. Raja Grafindo Persada
- [2] Agusta (2013) *Pengaruh Pelatihan dan motivasi kerja terhadap kinerja karyawan CV Haragon Surabaya?*
- [3] Anoraga (2005). *Manajemen Bisnis*, Cetakan ketiga, Jakarta : Rineka Cipta
- [4] Barry Cushway and Derek Lodge. 1993. *Organisational Behaviour and Design, Perilaku dan Desain Organisasi*. Jakarta: PT. Elex Media Komputindo.
- [5] Fadel.2009. *Reinventing Government (Pengalaman Dari Daerah)*.PT. Elex Media Komputindo. Jakarta
- [6] Hasibuan,M. (2003). *Organisasi dan Motivasi*, Jakarta: PT. Bumi Aksara.
- [7] Hasibuan,M. (2003). *Organisasi dan Motivasi*, Jakarta: PT. Bumi Aksara.
- [8] Hersey and Blanchard, (2012: *Nursing patients With acute Chest Pain: Practice Guided By The Prince Edward Island Conceptual Model for Nursing. Nurse Education In Practice. Emergency Room Nurse, Charlottetown, Prince Eduad Island, Canada B.School of Nursing, University of Prince Edward Island, Charlottetown, Prince Edward Island, Canada . Nurse education In Practice 10 (2012) 48-51.*
- [9] Imam Ghozali (2005). *Penggunaan Teknik Ekonometri*. PT. Raja grafindo Persada. Jakarta.
- [10] Jackson.2001, *Manajemen Sumber Daya Manusia.*, Jakarta : Buku kedua.
- [11] Kistoyo. 2008. *Pengaruh Kepemimpinan, Komunikasi Dan Lingkungan Fisik Terhadap Kinerja Pegawai Pada Kantor Dinas Pendidikan Kabupaten Pekalongan*. Tesis. Surakarta: Uniersitas Sebelas Maret.
- [12] Mangkunegara (2012). *Manajemen Sumber Daya Manusia, Ceakan Kelima,Bandung: PT. Remaja Rosdakarya.*
- [13] Mangkunegara (2012). *Manajemen Sumber Daya Manusia, Ceakan Kelima,Bandung: PT. Remaja Rosdakarya.*
- [14] Mas'ud (2004). *Survei Diagnosasional, Konsep dan Aplikasi*, Semarang: BP Undip.
- [15] Mulyadi, Dedy dan Rivai, Veithzal (2009). *Kepemimpinan dan Perilaku Organisasi*. PT. raja grafindo Prsada. Jakarta.
- [16] Munandar (2004) . *Anggaran Perusahaan, Edisi Tiga*, Jakarta: Salemba Empat.
- [17] Mursinta .2009. *hubungan motivasi dengan komitmen organisasi*, Jakarta: Grafindo.
- [18] Nawawi (2013). *Budaya Organisasi Kepemimpinan dan Kinerja*. Jakarta: PT. Fajar Iterpratama Mandiri.
- [19] Purwati, 2012. *Pengaruh Harga dan Kualitas Produk terhadap keputusan Pembelian Motor Honda Matic Beat (Studi Kasus pada PT Nusantara Solar Sakti)*, *Jurnal Ekonomi dan Informasi Akuntansi*, Vol 2, No.3, September 2012, Hal 262.2015.
- [20] Rowden (2000), *Komitmen Organisasi*, Jakarta: PT. Indeks
- [21] Setiawan, D. 2006. *Struktur komunitas makrozoobentos sebagai bioindikator kualitas lingkungan perairan hilir Sungai Musi*. Tesis. Sekolah Pascasarjana Institut Pertanian Bogor. 193hlm.

- [22] Siagan (2002). *Kepemimpinan Organisasi dan Perilaku Administrasi*, Jakarta: Penerbit Gunung Agung.
- [23] Sugiono (2011). *Metode Penelitian Bisnis (Pendekatan Kuantitatif, Kualitatif, dan R&D)*. Bandung: Alfabeta.
- [24] Suwanto and Pransia (2011) . *Manajemen SDM Dalam Organisasi Publik dan Bisnis*. Alfabeta. Bandung.
- [25] Yenny (2011). Verawati, Yenny, and Joko Utomo.2011. "Pengaruh Komitmen Organisasi, Partisipasi dan Motivasi terhadap Kinerja Karyawan pada PT Bank Lippo Tbk Cabang Kudus." *Analisis Manajemen*, Vol. 5, no. 2, 2011: 3.
- [26] Yukl, Gary A.2005. *Kepemimpinan Dalam Organisasi*, edisi kelima. Jakarta: PT INDEKS.